

HT-230

TIRE CHANGER WITH ZET BLASTER-TILT ARM & HELPER

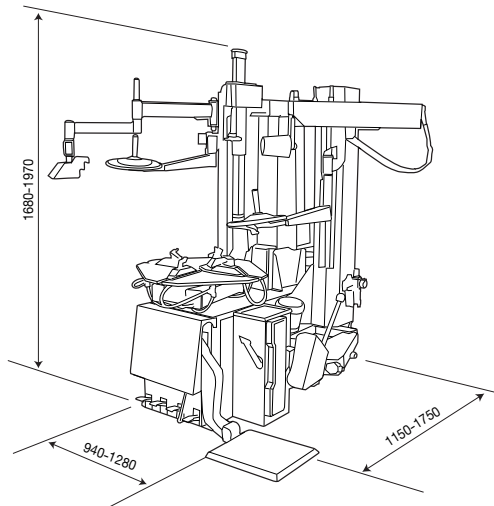

LAY-OUT



FEATURE

- High-Performed semi-automatic 4 foot pedals.
- Air bead breaker with double effect pneumatic cylinder.
- Plastic jaw cover to protect from the wheel damage.
- Simple and easy operate method.
- Tilting post by pedal controlled.
- Pneumatic left helper arm and right press arm for premium service operation.
- Pneumatic wheel lift for convenient and easy wheel adapt. (OPTION)
- Powerful motor.
- Manual swing arm.
- Tire air inflator.
- Jaw with jet-blaster for wide range of wheels.

SPECIFICATION

Model	HT-230	Motor Power	0.75kw
Bead-Breaker Force	3,000kgf	Power Supply	1ph/3ph 110/220V 50/60Hz
Max.Turntable Torque	1,200Nm	Weight	405 kg
Max. Wheel Width	350mm (15")		
Operating Pressure	10 bar (140psi)		