



# User Manual

PCE-EVSE 300 Electrical Vehicle Tester



User manuals in various languages (français, italiano, español, português, nederlands, türk, polski, русский, 中文) can be found by using our product search on: [www.pce-instruments.com](http://www.pce-instruments.com)

Last change: 4 November 2021  
v1.0



## Contents

<b>1</b>	<b>Safety notes</b> .....	<b>1</b>
<b>2</b>	<b>Specifications</b> .....	<b>2</b>
<b>3</b>	<b>Delivery scope</b> .....	<b>2</b>
<b>4</b>	<b>Safety symbols</b> .....	<b>2</b>
<b>5</b>	<b>Description of the safety symbols</b> .....	<b>3</b>
<b>6</b>	<b>Device description</b> .....	<b>4</b>
<b>7</b>	<b>Testing charging stations</b> .....	<b>5</b>
7.1	Connecting the electrical vehicle tester to the charging station .....	5
<b>8</b>	<b>Operation of electrical vehicle tester</b> .....	<b>7</b>
8.1	PE test .....	7
8.2	PP test signal .....	7
8.3	CP vehicle (simulation) .....	8
8.4	CP signal output (+ protective earth) .....	8
8.5	CP error test key "E" (simulation) .....	8
8.6	PE error test key (simulation) .....	8
8.7	Signal lamp for phase connection .....	8
8.8	Schuko plug connection .....	8
8.9	Phase measurement connection (L1, L2, L3, N, PE) .....	9
<b>9</b>	<b>Maintenance</b> .....	<b>9</b>
9.1	Cleaning .....	9
9.2	Transport and storage .....	9
9.3	Replace fuse .....	9
<b>10</b>	<b>Contact</b> .....	<b>10</b>
<b>11</b>	<b>Disposal</b> .....	<b>10</b>

## 1 Safety notes

Please read this manual carefully and completely before you use the device for the first time. The device may only be used by qualified personnel and repaired by PCE Instruments personnel. Damage or injuries caused by non-observance of the manual are excluded from our liability and not covered by our warranty.

- The device must only be used as described in this instruction manual. If used otherwise, this can cause dangerous situations for the user and damage to the meter.
- The instrument may only be used if the environmental conditions (temperature, relative humidity, ...) are within the ranges stated in the technical specifications. Do not expose the device to extreme temperatures, direct sunlight, extreme humidity or moisture.
- Do not expose the device to shocks or strong vibrations.
- The case should only be opened by qualified PCE Instruments personnel.
- Never use the instrument when your hands are wet.
- You must not make any technical changes to the device.
- The appliance should only be cleaned with a damp cloth. Use only pH-neutral cleaner, no abrasives or solvents.
- The device must only be used with accessories from PCE Instruments or equivalent.
- Before each use, inspect the case for visible damage. If any damage is visible, do not use the device.
- Do not use the instrument in explosive atmospheres.
- The measurement range as stated in the specifications must not be exceeded under any circumstances.
- Non-observance of the safety notes can cause damage to the device and injuries to the user.
- The tester must only be used by trained personnel.

We do not assume liability for printing errors or any other mistakes in this manual.

We expressly point to our general guarantee terms which can be found in our general terms of business.

If you have any questions please contact PCE Instruments. The contact details can be found at the end of this manual.





## 2 Specifications

Functions	
PE pre-test (protective earth)	available, error
PP simulation (charging cable coding)	open, 13 A, 20 A, 32 A, 63 A
CP simulation (communication line)	A, B, C, D, error
Outputs (for test purposes only)	
Measurement connections	L1, L2, L3, N, PE max. 250 / 430 V AC, 10 A laboratory plug
Schuko connection	max. 250 V AC, 10 A
Fuse of the Schuko connection	Fuse F 10 A / 250 V, 5 x 20 mm
CP signal output	±12 V PWM
Further specifications	
Input voltage	1-phase: 250 V AC / 3-phase 430 V AC, 50 / 60 Hz, max. 10 A
Charging cable plug type 1	AC charging mode 3, compatible with IEC62196-1 type 1 or SAE J1772 with vehicle connector (type 1, 5-pin, 1-phase)
Charging cable plug type 2	AC charging mode 3, compatible with IEC62196-2 type 1 or SAE J1772 with vehicle connector (type 2, 7-pin, 3-phase)
Measurement category	CAT II 300 V
Protection class	IP54
Degree of pollution	2
Operating conditions	0 ... 40 °C / 32 ... 104 °F, 10 ... 85 % RH, non-condensing
Storage conditions	-10 ... 50 °C / 14 ... 122 °F, 10 ... 85 % RH, non-condensing
Maximum working height	max. 2000 m / 6561 ft
Dimensions (handheld only)	277 x 109 x 63 mm / 10.9 x 4.3 x 2.4"
Weight	approx. 1 kg / 2.2 lb

## 3 Delivery scope

1 x electrical vehicle tester PCE-EVSE 300, 1 x charging cable plug type 1, 1 x charging cable plug type 2, 1 x transport bag, 1 x user manual

## 4 Safety symbols

Symbol	Meaning
	Follow the instructions
	Risk of electric shock
	Double insulation
	Connection must be made to the protective earth conductor "PE"
	Reference, please pay special attention

## 5 Description of the safety symbols

No.	Description
1	Risk of electric shock if the signal lamp lights up during the PE test. If this lamp lights up, no further tests must be carried out until the PE error has been rectified.
2	If the connections are incorrectly made, there is a risk of electric shock.

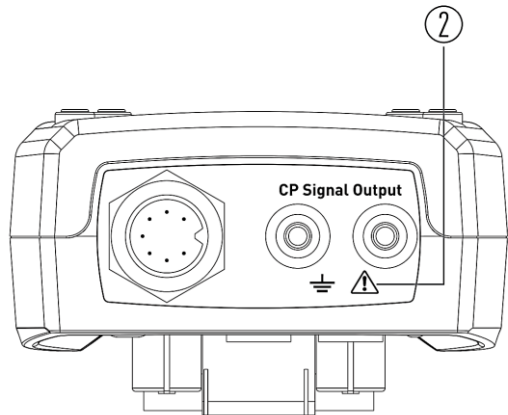
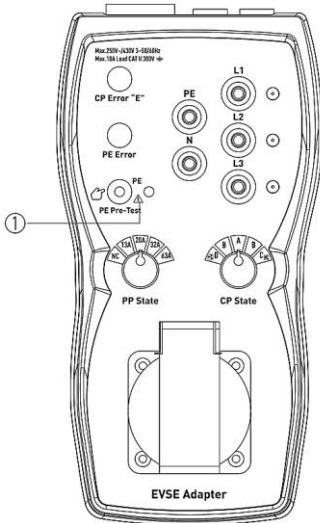

## 6 Device description

No.	Description
1	CP error test key "E" (simulation)
2	PE error test key (simulation)
3	PE test contact surface
4	PE test signal lamp
5	PP rotary selector switch (not connected, 13 A, 20 A, 32 A, 63 A)
6	Schuko connection plug
7	Schuko laboratory plug connection 4 mm
8	Phase laboratory plug connection 4 mm (L1, L2, L3)
9	Signal lamp for phase connection
10	Neutral conductor laboratory plug connection 4 mm
11	CP rotary selector switch A, B, C, D
12	Charging station connector (male)
13	Connection for charging station plug (female)
14	CP signal output
15	CP signal output connected to protective earth
16	Fuse

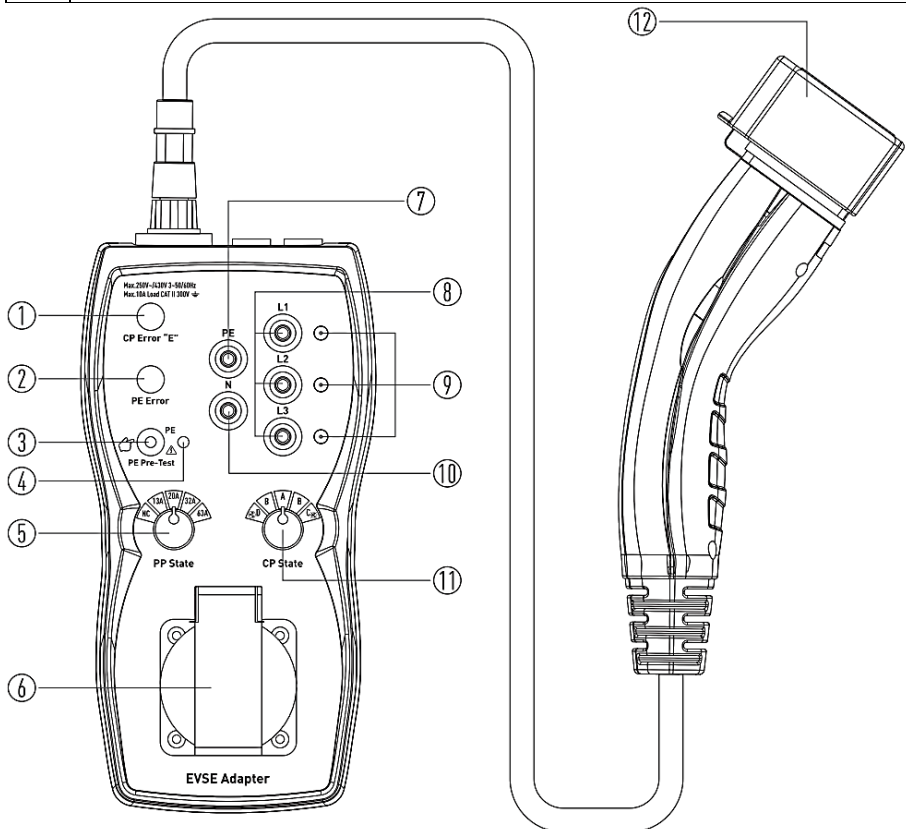

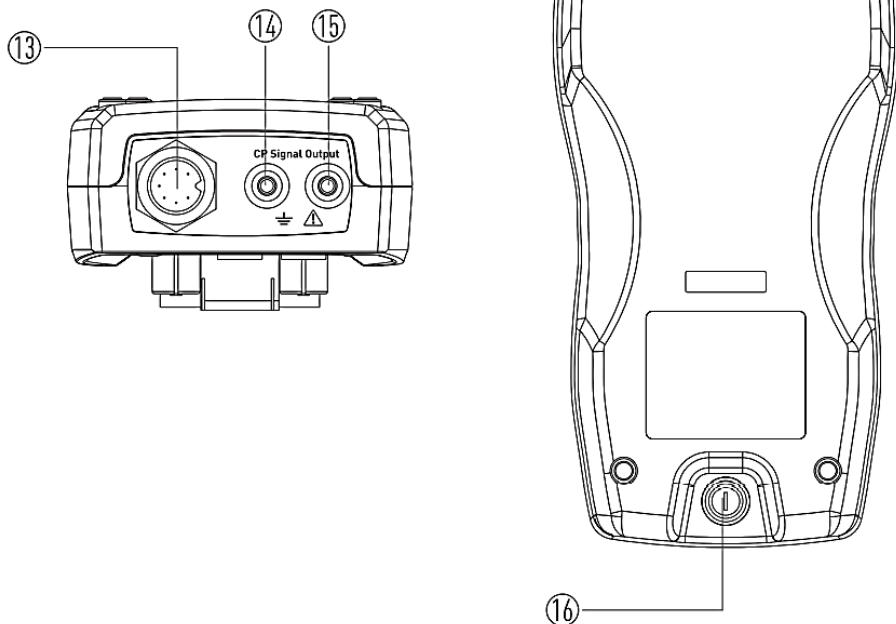

## 7 Testing charging stations

### 7.1 Connecting the electrical vehicle tester to the charging station

The electrical vehicle tester supports charging plugs of the types 1 and 2. To establish a connection, first select the appropriate plug and connect it to the electrical vehicle tester. You can then connect the charging plug to the charging station. Measurement with a permanently installed cable is also possible if an appropriate adaptor is connected in between.

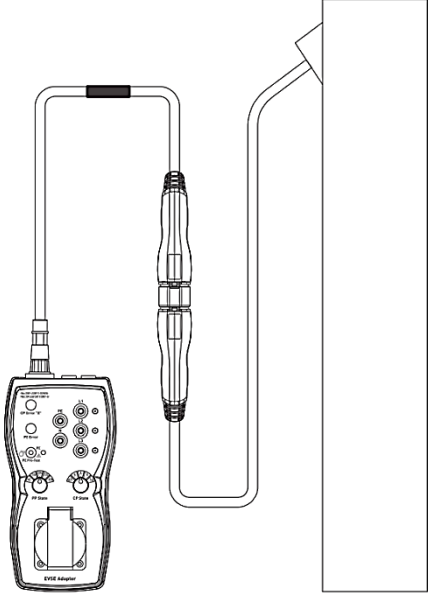
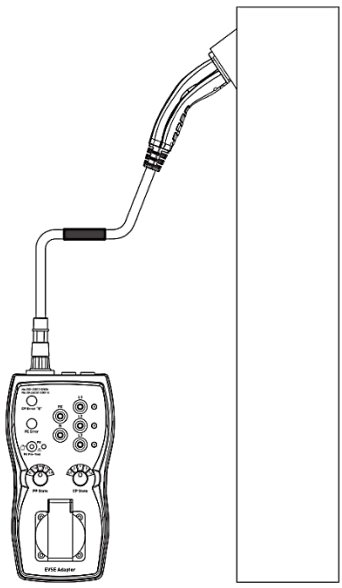
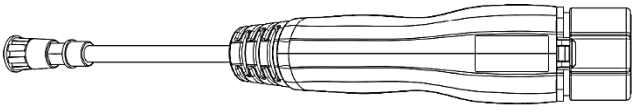
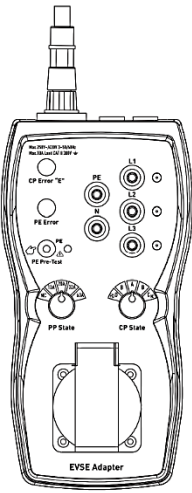

Direct connection to the charging station and connection via an adaptor with the permanently installed cable.



## 8 Operation of electrical vehicle tester

### 8.1 PE test

This test can be used to determine whether there is any external voltage on the protective earth conductor. Do not touch the protective conductor connection before the PE test is completed. Proceed as follows for the test:

1. Connect the adaptor to the charging station.
2. Touch the PE contact surface.

If the PE test signal lamp lights up during the test, there is a risk of electric shock as there is an external voltage on the protective conductor. No further work or tests should be carried out until this fault has been rectified.

**Note:** Make sure that you do not wear gloves during the test and that your hands are clean. This test does not guarantee absence of voltage.

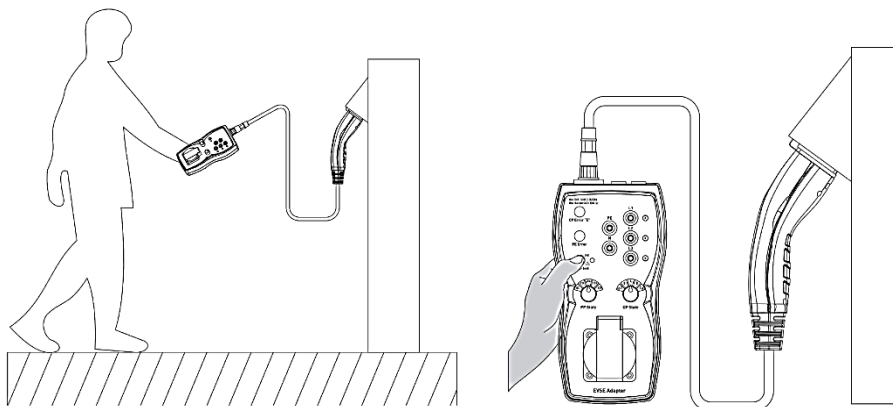

### 8.2 PP test signal

The PP test rotary selector switch can be used to simulate the cable type. For this purpose, a specific resistor will be connected between the PP cable and the protective earth conductor. This can be seen in the following chart:

Cable type	Resistor
No cable (NC)	Open
13 A	1.5 k $\Omega$
20 A	680 $\Omega$
32 A	220 $\Omega$
63 A	100 $\Omega$

### 8.3 CP vehicle (simulation)

The CP rotary selector switch can be used to simulate the vehicle side. The vehicle side is simulated by means of resistors between CP and the protective conductor. All specifications can be taken from the following table.

Vehicle status (switch position)	Explanation	Resistor between CP and PE	Voltage CP connection (1 kHz)
A	Vehicle is not connected	Open	$\pm 12$ V
B	Vehicle is connected and not ready to charge	2.74 k $\Omega$	+9 V / -12 V
C	Vehicle is connected and ready to charge	882 $\Omega$	+6 V / -12 V
D	Vehicle is connected and ready to charge. Ventilation is required.	246 $\Omega$	+3 V / -12 V

### 8.4 CP signal output (+ protective earth)

The CP output terminal is connected to CP and the protective earth of the charging station. The green terminal is directly connected to the protective earth. These terminals can be connected to an oscilloscope to check the output signal. Pulse width modulation (PWM) is expected. The signal should be designed according to IEC/EN 62851-1 and IEC/HD 60364-7-722.

### 8.5 CP error test key "E" (simulation)

The CP error test key simulates an error according to IEC/EN 6185-1. When this key is pressed, the CP signal is applied to the PE conductor via a diode. As a result, the charging process should be aborted.

### 8.6 PE error test key (simulation)

This key can be used to simulate a PE error. When pressing the key, the charging process should therefore be aborted.

### 8.7 Signal lamp for phase connection

The signal lamps indicate that voltage is present at the corresponding phase.

**Note:** If the neutral conductor is not connected, the signal lamp will not light up. The signal lamps do not signal the connected phase rotation direction.

### 8.8 Schuko plug connection

L1, N and PE in the charging station are tapped by the Schuko plug connection. This connection can be used to make power measurements, for example to check a current display.

**Note:** This connection is protected by the built-in 10 A fuse.

### **8.9 Phase measurement connection (L1, L2, L3, N, PE)**

Further meters can be connected via these laboratory plug connections in order to carry out measurements. This terminal is directly connected to the charging station.

**Note:** This terminal is for measurement only and must not be used for charging.

## **9 Maintenance**

No special maintenance is required for the tester. If any problems occur, the customer service must be informed.

### **9.1 Cleaning**

After use, the tester must be cleaned. Use a dry cloth and a mild household cleaning agent for this purpose. No aggressive cleaning agents should be used. Before cleaning, all cables must be disconnected from the tester. After cleaning, the meter may be used as soon as it is completely dry.

### **9.2 Transport and storage**

For transport and storage, the transport bag should be used to prevent damage. During storage, ensure that the tester is stored in a dry environment. If the tester is exposed to extreme temperatures during transport, it must first acclimatise for two hours.

### **9.3 Replace fuse**

If the fuse blows, it must be replaced. To do so, the tester must be disconnected from all lines. Ensure that there is no voltage. Then open the compartment for the fuse on the back and replace it by a 10 A (H) 250 V, 5 x 20 mm fuse. You can then close the compartment. The tester is now ready for use again.



## 10 Contact

If you have any questions, suggestions or technical problems, please do not hesitate to contact us. You will find the relevant contact information at the end of this user manual.

## 11 Disposal

For the disposal of batteries in the EU, the 2006/66/EC directive of the European Parliament applies. Due to the contained pollutants, batteries must not be disposed of as household waste. They must be given to collection points designed for that purpose.

In order to comply with the EU directive 2012/19/EU we take our devices back. We either re-use them or give them to a recycling company which disposes of the devices in line with law.

For countries outside the EU, batteries and devices should be disposed of in accordance with your local waste regulations.

If you have any questions, please contact PCE Instruments.





## PCE Instruments contact information

### Germany

PCE Deutschland GmbH  
Im Langel 4  
D-59872 Meschede  
Deutschland  
Tel.: +49 (0) 2903 976 99 0  
Fax: +49 (0) 2903 976 99 29  
info@pce-instruments.com  
www.pce-instruments.com/deutsch

### United Kingdom

PCE Instruments UK Ltd  
Unit 11 Southpoint Business Park  
Ensign Way, Southampton  
Hampshire  
United Kingdom, SO31 4RF  
Tel: +44 (0) 2380 98703 0  
Fax: +44 (0) 2380 98703 9  
info@pce-instruments.co.uk  
www.pce-instruments.com/english

### The Netherlands

PCE Brookhuis B.V.  
Institutenweg 15  
7521 PH Enschede  
Nederland  
Telefoon: +31 (0)53 737 01 92  
info@pcebenelux.nl  
www.pce-instruments.com/dutch

### France

PCE Instruments France EURL  
23, rue de Strasbourg  
67250 Soultz-Sous-Forets  
France  
Téléphone: +33 (0) 972 3537 17  
Numéro de fax: +33 (0) 972 3537 18  
info@pce-france.fr  
www.pce-instruments.com/french

### Italy

PCE Italia s.r.l.  
Via Pesciatina 878 / B-Interno 6  
55010 Loc. Gragnano  
Capannori (Lucca)  
Italia  
Telefono: +39 0583 975 114  
Fax: +39 0583 974 824  
info@pce-italia.it  
www.pce-instruments.com/italiano

### United States of America

PCE Americas Inc.  
1201 Jupiter Park Drive, Suite 8  
Jupiter / Palm Beach  
33458 FL  
USA  
Tel: +1 (561) 320-9162  
Fax: +1 (561) 320-9176  
info@pce-americas.com

### Spain

PCE Ibérica S.L.  
Calle Mayor, 53  
02500 Tobarra (Albacete)  
España  
Tel. : +34 967 543 548  
Fax: +34 967 543 542  
info@pce-iberica.es  
www.pce-instruments.com/espanol

### Turkey

PCE Teknik Cihazları Ltd.Şti.  
Halkalı Merkez Mah.  
Pehlivan Sok. No.6/C  
34303 Küçükçekmece - İstanbul  
Türkiye  
Tel: 0212 471 11 47  
Faks: 0212 705 53 93  
info@pce- cihazlari.com.tr  
www.pce-instruments.com/turkish